



T-4 Bliss Former

Standard Features

- Powder Coated Frame - Heavy Gauge welded Steel Construction
- Machined Aircraft Grade Aluminum Vacuum Scissor Assembly
- Venturi Vacuum Generator - No moving parts or electrical requirements
- Hardened Mechanical Drive Components
- Sealed No Maintenance Frame Bearings
- High Temp Solenoid Valves
- Nema 4X Electrical Enclosures
- Self Lubricating Vacuum Bearings
- High Capacity Hopper
- Portable Footprint– Standard machined wheels for hard surfaces
- 30+ Years of Experience

Options

- Stack light Beacon
- Stainless Steel Construction
- Custom powder coat
- Box Lidder



HR Spinner | 115 S 1st Avenue | Yakima, WA 98902 USA

Phone 800-876-4283 or (509) 453-9111 | Fax (509) 248-9712 | www.hrspinner.com



T4 Bliss Former Specifications	
Power Requirements	240 3Ø / 60 HZ
Air	80psi
Case Speed	Up to 30/min
Min. Case Size	Call for Details
Max Case Size	Call for Details

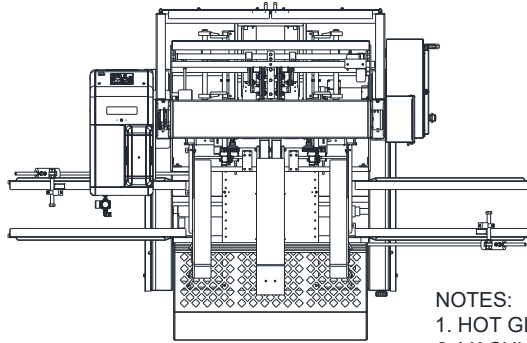

NOTES:

- 1. HOT GLUE TANK
- 2. VACUUM PICK ASSEMBLY
- 3. GLUE CONTROL PANEL
- 4. MAIN CONTROL PANEL
- 5. SPEED CONTROL
- 6. INFEED HOPPER
- 7. MANDREL SAFETY GUARD
- 8. SIDE WRAP HOPPER

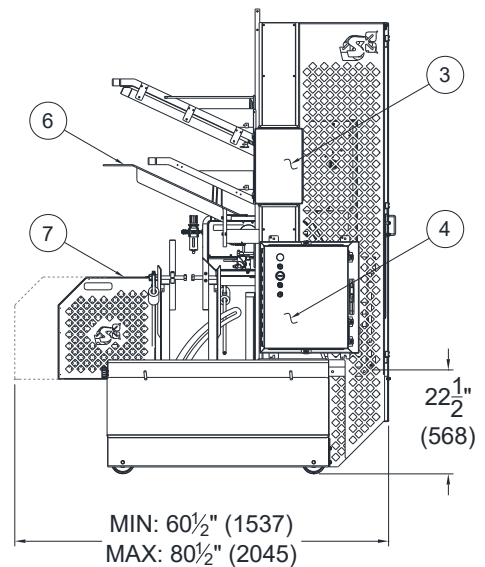
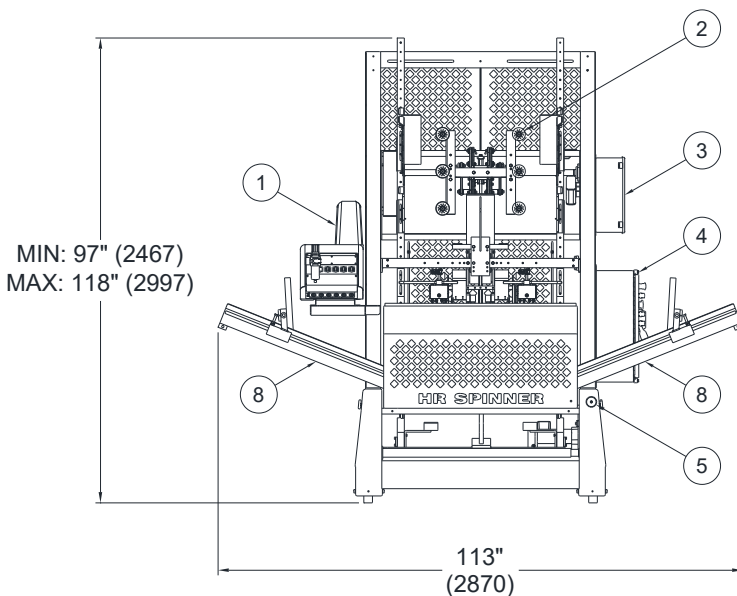

HR Spinner | 115 S 1st Avenue | Yakima, WA 98902 USA

Phone 800-876-4283 or (509) 453-9111 | Fax (509) 248-9712 | www.hrspinner.com