

## Pad Inserter

### Standard Features and Benefits

- Heavy duty stainless steel construction
- Easily integrated into a existing packaging line
- High intensity LED machine status lights
- Easy load/gravity feed hopper
- Dual pick and place heads
- High efficiency motor free operation
- Large infeed capacity for extended runtime
- Easy change over for different size pads

### Box Entry (must specify)

- RH     - LH (shown)

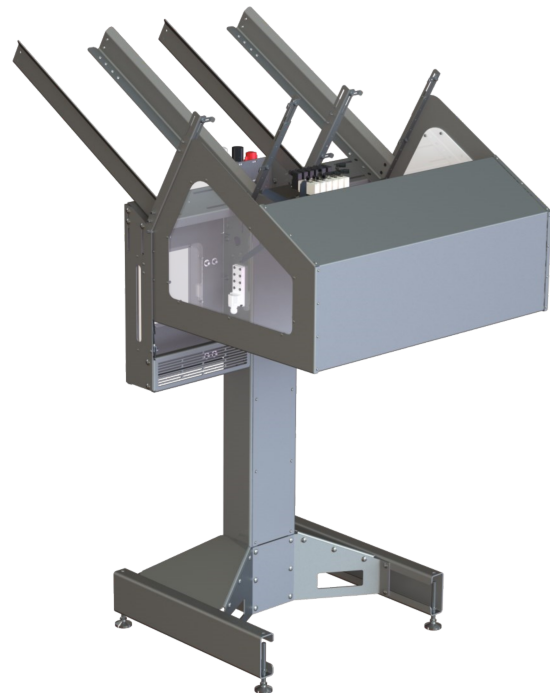



Pad Inserter Specifications	
Power Requirements	120 1PH
Air	60psi
Pad Speed	*Up to 40-60/min

\*Varies on configuration

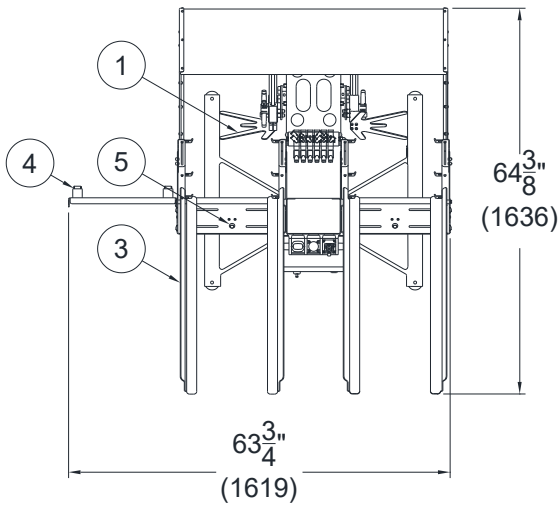

**NOTES:**

- 1. ROTARY PICK ASSEMBLY
- 2. MAIN CONTROL CABINET
- 3. INFEED HOPPER
- 4. PASS THRU SENSOR
- 5. HOPPER SENSOR
- 6. BEACON LIGHT (EA SIDE)

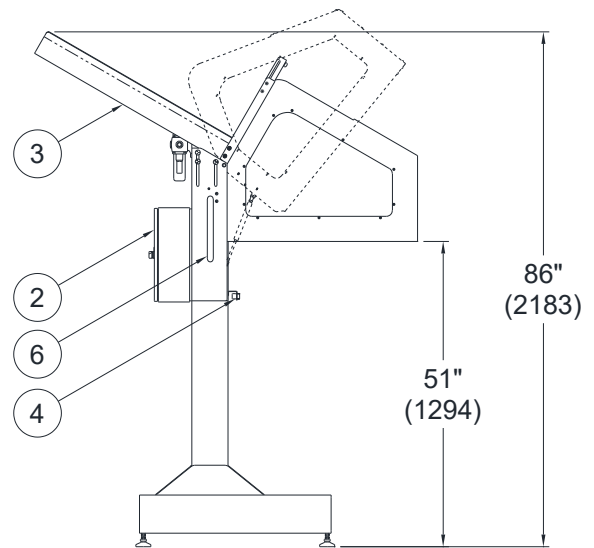
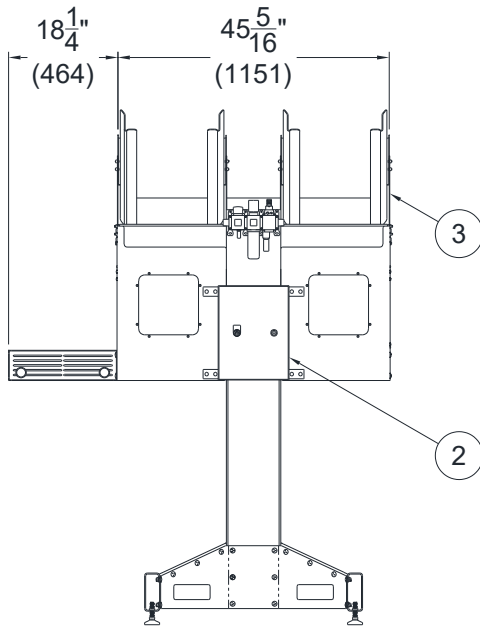

HR Spinner | 115 S 1st Avenue | Yakima, WA 98902 USA

Phone 800-876-4283 or (509) 453-9111 | Fax (509) 248-9712 | [www.hrspinner.com](http://www.hrspinner.com)