



PENINSULA
PACKAGING COMPANY
www.penpack.net



Cherry Clamshells



Features:

- Meets the Sustainability Packaging Requirements of Major Retailers (eg Costco, Sam's, Wal*Mart)
- Top and Bottom Hole Vents
- Secure "Dog Bone" Pin-Locks
- Self Aligning Locking Pins
- Secondary Lid-to-Base "Bridge" Supports
- Costco - Approved
- Denesting Lugs for Easy Separation
- 5-Down Footprint
- Made with up to 100% Tough Recycled PET Drink Bottles
- Made with up to 50% Clean Solar Non-Polluting Energy from the Sun
- International Resin Codes
- Made in USA

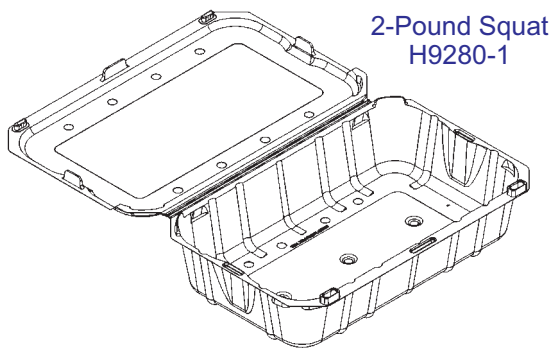

2-Pound Squat
H9280-1

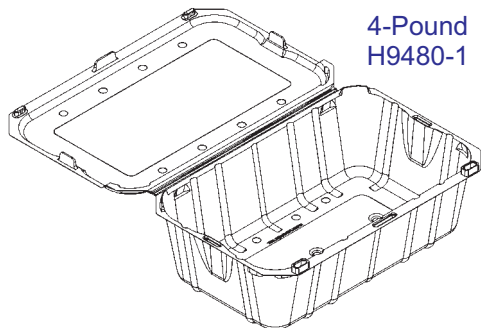

4-Pound
H9480-1

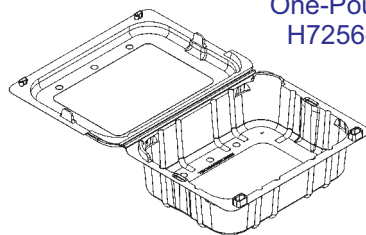

One-Pound
H7256-1

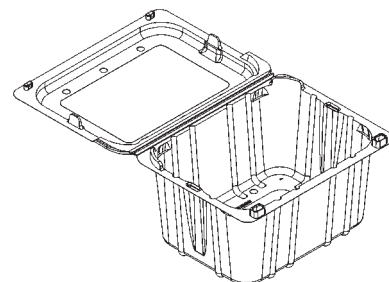

2-Pound
H7456-1

Patented Designs
PAT NO D569243

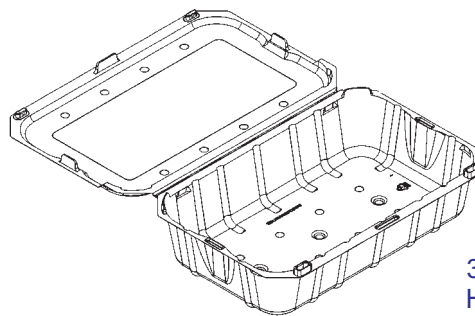

3-Pound
H9382-1

See Other Side for Specifications



Many produce items are available labeled with top and bottom labels.
All produce items are made from PET plastic and contain up to 100% post-consumer recycled drink bottles.
Up to 50% self-generated clean energy from the SUN is used in the manufacturing of Peninsula's packaging products.
Contact your Peninsula sales representative for details.

Facility Locations:

Yakima, WA
(509) 575-5341
Corp Offices
Exeter, CA
(559) 594-6813
sales@penpack.net











Hollister, CA
(831) 634-0940

Wilson, NC 27894
(252) 265-5590

ncsales@penpack.net



CHERRY CLAMSHELLS

Description	Product Picture	Item Number(s)	Outside Dimensions - Inches (mm)				Inside Dimensions - Inches (mm)				Closure	Case Count	Cases per Pallet
			Length	Width	Height	Closed Height	Length	Width	Height	Closed Height			
Pint Modular Hinged-Lid (8 oz Modular)		H6250	5-1/2 (140)	4-1/16 (103)		2-1/2 (64)	4-7/8 (124)	4-5/16 (109)		2-5/16 (59)	Perimeter	390	30
300 gram Cherry Clamshell		H7156	7-1/8 (181)	5-5/8 (143)		1-15/16 (49)	6-5/8 (168)	5-1/8 (130)		1-15/16 (49)	Patented "Dog Bone" Pin Locks	300	24
3/4 lb Cherry Clam		H7257	7-1/8 (181)	5-5/8 (143)		1-1/2 (38)	6-5/8 (168)	5-1/8 (130)		1-1/2 (38)	Patented "Dog Bone" Pin Locks	220	24
1 lb. Cherry PAT NO D569243		H7256-1	7-1/8 (181)	5-5/8 (143)		2-11/16 (68)	6-5/8 (168)	5-1/8 (130)		2-11/16 (68)	Pins Patent Pending	260	24
2 lb Grape Tomato		H7380	7-1/8 (181)	7-7/16 (179)		3 (76)	6-3/4 (171)	6-1/2 (165)		2-7/8 (73)	Perimeter	252	24
2 lb. Cherry PAT NO D569243		H7456-1	7-1/8 (181)	5-5/8 (143)		4-1/16 (103)	6-5/8 (168)	5-1/8 (130)		4-1/16 (103)	Pins Patent Pending	240	24
1 lb 8 Down Squat Clamshell		H9255	9-7/16 (240)	5-1/2 (140)		1-5/8 (41)	9-1/8 (232)	5 (127)		1-5/8 (41)	Pins Patent Pending	340	24
2 lb. Squat Cherry PAT NO D569243		H9280-1	11 (279)	7-1/4 (184)		2-1/4 (57)	10-1/2 (267)	6-3/4 (171)		2-1/4 (57)	Pins Patent Pending	150	24
3 lb. Cherry PAT NO D569243		H9382-1	11 (279)	7-1/4 (184)		2-13/16 (71)	10-1/2 (267)	6-3/4 (171)		2-13/16 (71)	Pins Patent Pending	140	24
4 lb. Cherry PAT NO D569243		H9480-1	11 (279)	7-1/4 (184)		3-11/16 (94)	10-1/2 (267)	6-3/4 (171)		3-11/16 (94)	Pins Patent Pending	110	24



Many produce items are available labeled with top and bottom labels. Contact your Peninsula sales representative for details.
 All produce items are made from PET plastic and contain up to 100 percent post-consumer recycled materials.
 Clean energy from the SUN is used in the manufacturing of Peninsula's packaging products.
 Dimensions are to be used as guidelines only. Application should be verified from product samples.
 Subject to change without notice.